



*Daystate* 

**RED WOLF**  
**OFFICIAL HANDBOOK**



## CONTENTS

3. FILLING YOUR AIR RIFLE WITH COMPRESSED AIR
4. LOADING YOUR RIFLE (SINGLE-SHOT MODE)
4. LOADING YOUR RIFLE (MULTI-SHOT MODE - SELF-INDEXING MAGAZINE)
5. SWITCHING SIDELEVER POSITION
6. BATTERY OPERATION & MAINTENANCE
7. PROGRAMMING THE RIFLE
8. STOCK ADJUSTMENTS
9. SAFETY SWITCH
9. ADJUSTING THE TRIGGER
10. PELLETS RECOMMENDATIONS
10. FITTING A RIFLE SCOPE
11. MAINTENANCE
12. DIAGRAM OF PARTS
14. WARRANTY INFORMATION

## SAFETY

- Never point your air rifle at anyone, nor at anything other than a legitimate target
- Always check your air rifle is not loaded when you first pick it up
- Always treat your air rifle as if it was loaded, even if you know it is not
- Always store your air rifle and pellets securely and separately so that no unauthorised person can access or use them
- Never store your air rifle with a pellet in the breech
- Never shoot on land where you do not have permission to shoot
- Always use a safe, large backstop to catch your pellets – and pay due attention to what is behind the target, should you miss
- Never leave your air rifle unattended
- Know and abide by the air rifle laws in your country/state

## GENERAL INFORMATION

Congratulations on choosing a Daystate precharged pneumatic (PCP) air rifle. Your rifle has been hand assembled using the finest materials available, from parts precision-made on CNC engineering technology. All rifles are UK-made to the highest quality standards. Before leaving the factory, each rifle is tested for power, consistency and pellet-grouping accuracy to ensure it meets the performance and reliability expected of an air rifle carrying the prestigious Daystate marque. We also ensure your rifle complies with the latest PCP safety and product-testing protocols.

This rifle is the culmination of Daystate's involvement with PCP air rifles for over 40 years, making it one of the most accurate and reliable air rifles available. Use this handbook to help you get the best from it. The latest information and updates can be found online at:

[daystate.com/handbooksguides](https://www.daystate.com/handbooksguides)



Daystate also has an active Owners' Club. This is free to join and is online at:

[daystateownersclub.com](https://www.daystateownersclub.com)





# FILLING YOUR AIR RIFLE WITH COMPRESSED AIR

Your Daystate PCP needs to be filled with compressed air from a separate charging unit, either a scuba tank or manually operated stirrup pump. The rifle should be refilled when the rifle's LCD information screen displays 'Low Pressure'.

- To access the rifle's filling valve, remove the magnetic dust cap in the belly of the forestock to reveal the filler port (1)

- Having securely fitted the supplied snap-on connector to your charging unit's filler hose assembly, lock the snap-on connector to the filling valve (2). Ensure the snap-on connector's outer sleeve has fully locked it on to the filling valve (3)

- To fill the rifle's main air reservoir with compressed air, ensure the charging unit's 'bleed' valve is closed, and then either:

  - (Scuba tank) SLOWLY open the unit's main feed valve (4)

  - (Stirrup pump) Begin pumping

- Note the pressure indicated on either the charging assembly's pressure gauge or the rifle's LCD information screen (5). You should fill the rifle to the following charging pressure:

  - Maximum 250BAR (3,600psi). The rifle's maximum pressure (SWP) will vary according to model and is indicated by way of a small pressure disc on the individual rifle (5).

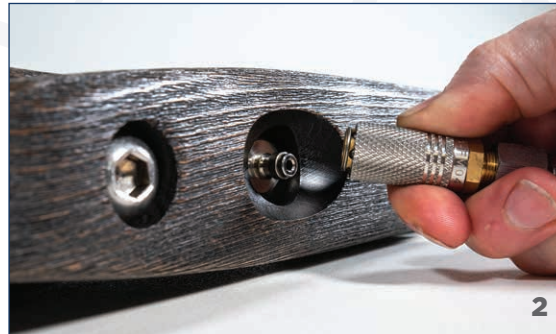

## Use ONLY clean, dry, compressed air

- Once the correct pressure has been reached, either:
  - (Scuba tank) Fully close the main valve
  - (Stirrup pump) Stop pumping
- Then open the charging unit's bleed valve to rapidly bleed off the remaining air in the filler hose
- Remove the snap-on connector from the rifle and replace the magnetic filler port cover

# LOADING YOUR RIFLE - SINGLE SHOT MODE & MULTI-SHOT MODE

The Daystate Red Wolf can be fired in single or multi-shot modes. In single-shot mode, a loading tray is placed in the breech to facilitate hand-loading into the breech for each shot. Multi-shot mode uses a removable, spring-operated, rotary magazine to automatically present pellets to the breech, and therefore allows quicker shooting.

## IMPORTANT:

- **To prevent damage to the rifled barrel, only use soft metal pellets**
- **Keep the muzzle of your air rifle pointing in a safe direction at all times**
- **Always ensure the last shot has been fired from the barrel at the end of a shooting session, especially when multi-shot mode has been deployed**
- Engage the safety catch at the rear of the action by sliding it to the left
- Open the sidelever and remove the plastic single shot tray or self indexing magazine from the right (if fitted)



• Open the front-loading gate on the magazine and rotate the inner drum one rotation clockwise (fig.1)

• While holding the drum against spring tension, insert a pellet into the lower magazine chamber (fig.2). The magazine drum can now be released

• Insert pellets into the remaining chambers (fig.3) and close loading gate when the magazine is full

• Insert a loaded Daystate self indexing magazine into the right side of the rifle

• Push the side lever forward



## THE RIFLE IS NOW LOADED

- Disengage the safety catch and the rifle is ready to fire
- After the shot is taken, recycling the side lever will cock the rifle and allow the magazine to automatically index; the next pellet will be chambered on the lever's return.

Note: The magazine will index each time the sidelever is cycled. To avoid a 'double-load' do not recycle the side lever without having first fired the rifle.

The rifle can be dry fired with no pellets in the breech - without any mechanical damage occurring provided there is air in the rifle. A single shot tray is provided for use in a target setting, insert with the direction arrow pointing forward towards the muzzle.

If the rifle's magazine countdown program has been set to "Magazine On", four small pulses will be felt immediately after the last shot has been discharged, and the LCD information screen will read "Mag Empty MO".



In the case of the Red Wolf and Wolverine models, the stop-pin locates in the upper and outermost hole – Huntsman models use the inner lower stop-pin hole (fig.4).



(fig.4)

## SWITCHING THE COCKING SIDELEVER POSITION

To complement the Red Wolf's ambidextrous stock, its cocking sidelever can be changed to operate from either the right or left-hand side of the action by the user, as follows:

- With a 2.5mm hex tool, unscrew and remove the pivot/bolt on the top, rear of the breech block (fig.1)



- Extract the complete sidelever and probe assembly (fig.2)



- Use a 2mm hex tool to loosen (but not remove) the two, small hex-head bolts visible through the exposed breech block opening. A quarter turn is all that is needed (fig.3)



- Slide the blanking plate out of the rear of the breech block (fig.4)



- Refit the blanking plate on the opposite side, and re-tighten the hex-head bolts to secure in place
- Re-insert the sidelever and bolt assembly on the opposite side, and secure in place by refitting the pivot/bolt. Do not overtighten
- Using a 2.5mm hex tool, relocate the sidelever's cocking handle to the underside of the lever



# BATTERY - OPERATION & MAINTENANCE

THE RIFLE IS POWERED BY A RECHARGEABLE LITHIUM POLYMER (LI-PO) BATTERY, LOCATED IN THE GRIP OF THE STOCK. THIS BATTERY MUST BE REMOVED TO BE RECHARGED WHEN ITS VOLTAGE DROPS BELOW THE REQUIRED LEVEL

- When the LCD information display shows “Low Battery”, ensure the rifle is not loaded, and then apply the safety catch (slide to left)
- Open the battery door at the base of the pistol grip
- Detach the battery from the rifle by disconnecting the bayonet terminal and extract the battery.
- DO NOT pull on the wires; disconnect the battery holding the bayonet terminal
- Recharge the battery using the supplied universal battery charger
- Once the battery is charged, reconnect it to the rifle by reversing the above procedure



Note: A fully-charged battery will provide enough power for many hundreds of shots.

*\*Follow the manufacturer's documentation that accompanies the universal battery charger when charging*

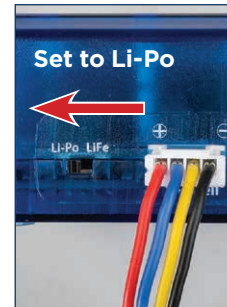
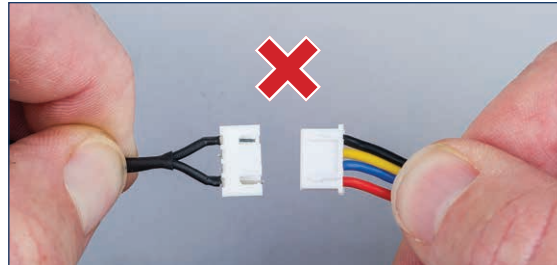
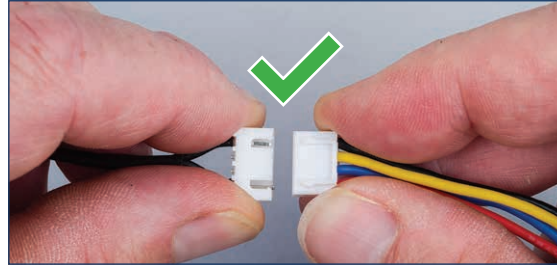

When charging, and battery is below 80%, cell one and two will light RED as per photo



When charging, and battery is between 80% and 90%, cell one and two will light as per photo



When charging completed, all LED's will be a solid BLUE.

*\*Note: Refer to charger manufacturer product instructions provided for further detail*

# PROGRAMMING THE RIFLE

## PROGRAM MODE

Before putting the rifle into program mode, ensure it is unloaded and engage the safety catch at the rear of the action by sliding it to the left. The following procedures should always be carried out with the muzzle pointing in a safe direction:

- Pull back the trigger, maintaining pressure for five seconds. Release the trigger when the LCD information display indicates “Programming Mode.” To exit Programming mode move the safety to the fire position and then back to safe.

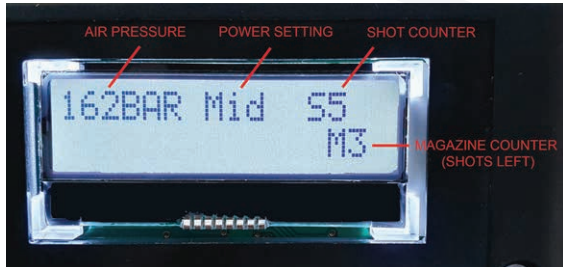

The Red Wolf's GCU electronic system provides the user five resettable settings:

**Magazine Size:** Choose from: 5, 7, 8, 10, 11, 13, OFF

**Power Level:** Choose from: Hi, Med, Low

**Sleep Time:** Choose from: 15 mins, 30 mins or 4 hrs

**Display (light) Timer:** Choose from: always on, 15 sec, OFF

**Shot Counter Reset:** Choose from: YES/NO

## MAGAZINE SIZE

To switch on or off the Magazine Size program, put the rifle into Program mode and scroll through until you get to Magazine size settings. Move the safety to the fire position and then back to safe to confirm the setting. The rifle will give a confirmation click.

Choose the setting corresponding to your magazine capacity which varies depending on calibre and region. The rifle will count down to “M0” as each shot is taken. After the final shot, the rifle will generate four pulses – vibrations easily felt by the shooter – and the rifle cannot be fired further.

- To reset the magazine counter and resume firing with a fresh magazine, open the sidelever and leave it open for a period of five seconds. The magazine may be ‘topped up’ at any point. However, if the countdown mode is on the magazine counter will require a reset by repeating the switch-on procedure above
- With magazine countdown “Off”, the rifle will not count down the shots in the magazine. This is the recommended setting when shooting the rifle in single-shot mode (manual loading).

## POWER LEVEL

To alter the Power Level program, put the rifle into Program mode and scroll through until you get to Power Level settings.

- With power level set to “Hi Power”, the rifle will shoot at its maximum output (dependent on model)
- With power level set to “Mid Power” or “Low Power”, the rifle will shoot at a percentage of its maximum power. The exact amount for each setting is dependent on model and pellet, but Mid is approximately 85% of Hi Power and Lo is 65% of the Hi Power setting. Move the safety to the fire position and then back to safe to confirm the setting. The rifle will give a confirmation click.

## SLEEP TIMER

To save battery and as a safety procedure, the rifle will power down into standby (power save) after 15 minutes. You can choose to extend the period before the rifle powers down to 30 minutes or 4

hours. To adjust the sleep timer put the rifle into Program mode and scroll through until you get to sleep timer settings.

**Note:** Extending the sleep timer will reduce battery life. If the rifle goes into standby (power-save) mode, it will be necessary to switch the safety catch on and off (slide right, then left) in order to power up the rifle.

To wake the rifle after it enters standby mode toggle the safety catch - It is not necessary to recycle the sidelever.

## DISPLAY TIMER

The back light on the LCD display can be adjusted to illuminate for 15 seconds, OFF, or Always On. To adjust the sleep timer, put the rifle into Program mode and scroll through until you get to Display Timer settings. Regardless of settings, when the safety is set to ‘safe’ the display light will go off after 20 seconds.

## SHOT COUNTER RESET

The LCD display shows the amount of shots taken. To reset the counter to 0, put the rifle into Program mode and scroll through until you get to SHOT COUNTER RESET. Toggle to YES to reset the counter.

**Notes:** In addition to the user program options, there are two further features that automatically apply where relevant. In both cases, the LCD information screen will display the rifle's status:

- “Low Battery” - the battery will need to be recharged
- “Low Pressure” - the rifle's air cylinder will need to be refilled. The pressure at which the warning will show is dependent on the calibre, maximum energy, and the selected power setting.

# STOCK ADJUSTMENTS

## STOCK

The Red Wolf's ambidextrous stock incorporates an adjustable cheekpiece and butt pad, allowing the shooter to dial-in a perfect gunfit. The stock also houses the Li-Po battery that provides power to the action.

## CHEEKPIECE ADJUSTMENT

- Loosen the bolt located on the right of the butt with a 5mm hex tool to raise or lower the



cheekpiece to the desired comb height. Ensure the bolt is re-tightened after adjustment



- The lateral and fore/aft positions of the cheekpiece can also be adjusted. To do this,

completely remove the cheekpiece and adjust its position by loosening/re-tightening the hex-head bolts on the underside of it. Use a 4mm hex tool to adjust the lateral position; a 3mm hex tool for the fore/aft position

## BUTT PAD ADJUSTMENT

- Loosen the bolt in the centre of the butt-pad with a 5mm hex tool to raise or lower the butt pad. Ensure the bolt is re-tightened after adjustment



- The butt pad cast (left/right angle) pad can also be adjusted. To do this, completely remove the butt pad and adjust to the desired angle by loosening/re-tightening the small hex-head bolts with a 2.5mm hex tool.



## STOCK REMOVAL

The Red Wolf's stock is removed from the action by unscrewing the 8mm hex-head screw in the belly of the rifle's forestock.



### Notes:

Unplug and remove the rechargeable Li-Po battery before removing the stock





## SAFETY SWITCH

The Red Wolf is fitted with a manually-operated safety catch switch, located at the rear of the action. To engage this to 'safe' (safety on), slide the switch to the left.

To disengage it to 'fire' (safety off), slide it to the right. The safety switch doubles up as an on/off switch for the rifle's electronics. The safety catch should always be returned to safe immediately after firing. For safety and power management reasons, the Red Wolf's electronic action has an adjustable auto-safety feature that by default powers down a 'live' rifle after 15 minutes (see p7 to adjust the delay time).



## TRIGGER ADJUSTMENT

The Red Wolf is fitted with a match-quality, two-stage trigger which has been expertly set at the factory for a safe, crisp let-off. While the end-user can adjust the trigger's travel, pull-weight and blade position for personal preference with a 1.5mm hex tool. It is not necessary to remove the rifle's action from the stock to undertake trigger adjustment.

### Note:

Always ensure the rifle's safety switch is in the 'safe' position (slide to left) and that rifle is unloaded if making a trigger adjustment.

Screw A: Second stage contact screw - factory-set (Do not adjust)

Screw B: Second stage weight screw. Turn clockwise to make trigger pull heavier

Screw C: First stage weight screw. Turn clockwise to make heavier

Screw D: First stage travel screw. Turn clockwise to decrease trigger travel

Screw E: Trigger blade adjustment screw. Loosen/re-tighten to adjust trigger blade to desired position\*

Screw F: Trigger shoe adjustment screw. Loosen/re-tighten to adjust shoe to desired position

*\*The Match trigger blade requires a 0.9 mm hex tool for adjustment of the trigger blade.*

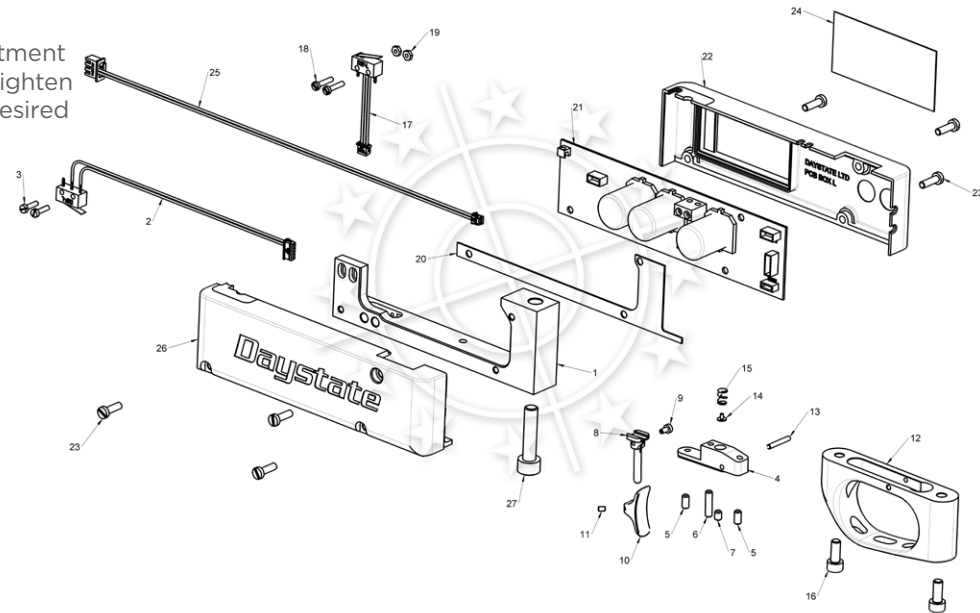
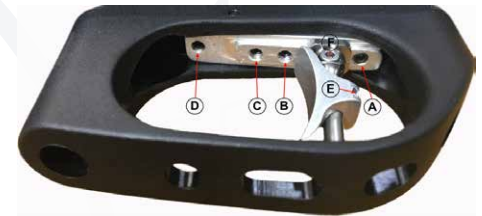

## PELLET RECOMMENDATIONS

The power, accuracy and consistency of your Red Wolf relies on the quality of the pellets and slugs used. The algorithms used in the Red Wolf programming have been achieved using Rangemaster ammunition. Daystate advises the following:-

### Up to 12 foot-pounds energy

- **Rangemaster Sovereign\***  
.177 (8.44gr)  
.22 (15.9gr)
- **Rangemaster Sovereign Hunter**  
.177 (10.3gr)  
.22 (18.3gr)
- **Rangemaster Kaiser**  
.177 (8.64gr)  
.22 (14.66gr)

### Up to 30 foot-pounds energy

- **Rangemaster Sovereign Hunter**  
.177 (10.3gr)  
.22 (18.3gr).
- **Rangemaster King**  
.177 (13.42gr)  
.22 (25.38gr).

### Up to 40 foot-pounds energy

- **Rangemaster King**  
.177 (13.42gr)  
.22 (25.38gr).

### Over 40 foot-pounds energy

- **Rangemaster Emperor Lite**  
.30 (44.75gr).
- **Rangemaster Emperor**  
.177 (15.89gr) .22 (33.95gr)  
.25 (33.95gr) .30 (50.15gr).
- **Rangemaster Juggernaut**  
.22 (25.3gr).  
.25 (33.49gr).

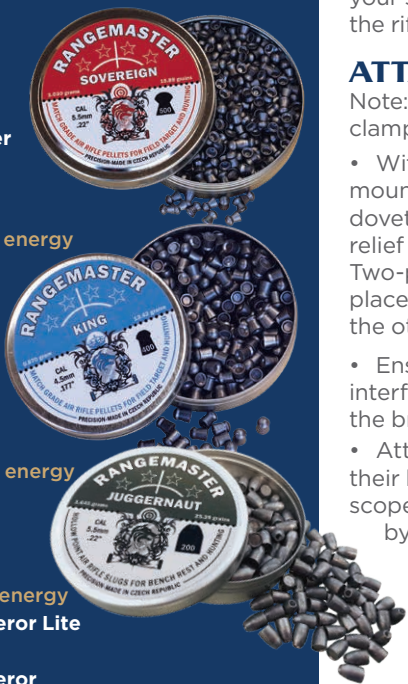

\*Set-up pellet for UK specification 12ftlb rifles

## FITTING A RIFLESCOPE

For maximum accuracy, your Daystate rifle requires a separate riflescope (telescopic sight) to be mounted, although other sighting devices (e.g.: red-dot, reflex, night-vision) may also be used. Daystate recommends riflescopes from MTC Optics ([www.mtcoptics.com](http://www.mtcoptics.com)), and two-piece adjustable BluePrint mounts. You should choose your scope and mounts with due consideration to the rifle and your shooting needs.

### ATTACHING THE MOUNTS

Note: select a scope mount with the correct clamp/height/ring size.

- With the top straps removed to expose the mount cradles, position the mounts on the rifle's dovetails in a position that allows the correct eye-relief of the scope when you are aiming the rifle. Two-piece style mounts are recommended – one placed on the front section of the breech block, the other on the rear
- Ensure the saddle of the scope does not interfere with the magazine if one is inserted into the breech
- Attach the mounts' top straps, but only nip-up their bolts finger tight – just enough to stop the scope turning freely, but still allow it to be rotated by hand

### CROSSHAIR ALIGNMENT

- Using a gun-vice or similar, place a spirit level across the rifle's breech block to ensure it is level
- Look through the scope and rotate it until the crosshairs are perfectly vertical and horizontal. You can use a plumb line downrange as an aid
- Once the crosshairs are aligned to the rifle, tighten all the mount ring bolts to their recommended torque



### ZEROING THE SCOPE TO THE RIFLE

- In front of a safe, suitable backstop, set up a large paper target with a visible mark in the centre around 10 metres (12 yards) away. This may be closer than the distance you prefer to shoot at, but it is a method used to initially zero your rifle/scope
- Aiming at the mark, fire a few pellets and note where they land
- Turn the scope's elevation and windage turrets the required amount to move the group toward the aiming mark, and repeat the procedure until the shots impact roughly at the aim point
- Then move the target to your primary zero distance and fine-tune the scope's elevation and windage turrets until the rifle/scope combo is precisely zeroed-in

#### Notes:

If the initial shots group more than 13cm (5ins) below the aim point, then the rear mount may need to be 'adjusted up' to provide enough adjustment on the scope's elevation turret. In this instance, place a sliver of silver foil, folded to a maximum thickness of 0.3mm, between the scope and the mount's lower cradle. Do not over-pack the mount, however, as this may damage the scope.



# MAINTENANCE

## RECOMMENDED MAINTENANCE

Precharged pneumatic (PCP) air rifles operate under extremely high pressures of compressed air, so can potentially become dangerous if not serviced correctly. There are no user-serviceable parts on a Daystate PCP, so any gunsmith work should ALWAYS be carried out by a factory-trained technician. Correct and regular maintenance also ensures your rifle will operate at peak performance. We therefore recommend that the rifle be returned to the factory or a Daystate-approved agent for a routine service **every three years**.

Between service intervals, however, you can keep your rifle shooting trouble-free by paying due attention to the following areas:

### AIR RESERVOIR

The Red Wolf's bottle will withstand pressures many times the working pressure of the rifle. The air bottle/cylinder should be inspected and or replaced every 10 years.

### CHARGING UNIT – HAND PUMP

A hand-operated stirrup pump offers an inexpensive and convenient method of charging your rifle. However, as most do not contain water extraction and dirt removal systems, they can shorten the life of sealing valves and O-rings. If you regularly use this type of charging unit, care should be taken to avoid condensation build-up from inside the pump being transferred to the rifle. The pump should not be used in sandy or dusty conditions.



Always refer to the pump manufacturer's operating instructions.

### CHARGING UNIT – SCUBA TANK

If you use a scuba tank to charge your rifle with compressed air, make sure you open its main feed valve slowly when transferring air from the tank to the rifle. Keep all charging connectors clean and free from oil. ALWAYS handle the charging unit carefully, and NEVER blast high pressure air directly onto your skin.

### CHARGING UNIT – COMPRESSOR



There are now electronic and petrol-engine compressors that can deliver breathing quality air. While these are suitable to directly fill your Daystate PCP, ensure that you do not

inadvertently fill your rifle with more than the recommended pressure.

For more details on the Daystate compressor go to [daystate.com/rifles/daystate-t2-compressor](http://daystate.com/rifles/daystate-t2-compressor).



### ACTION

After every shooting session, protect your rifle's metal parts with a corrosion inhibitor specifically for gun use. Apply the oil to a cloth and wipe over the gun. Do not apply oil to the rifle's filler valve.

### LUBRICATION

To maintain smooth cocking, sparingly lubricate the shaft of the bolt with a light grease

periodically, but do not allow any grease to get into the barrel, nor any internal parts such as the firing valve or hammer assembly. The snap-on filling connector is factory-lubricated with a special, non-combustible grease; it should be wiped over with an oily rag, but left 'dry'. Wipe over the action with an oily rag after each shooting session.

### BARREL CLEANING

For optimum performance, the barrel should be periodically cleaned with a barrel cleaning solution recommended for air rifles, or a pellet lubricant. Daystate also advises the use of a lubricant applied to the pellets to reduce lead deposits and maintain good barrel condition. Cleaning frequency depends on the pellet type used and the individual barrel; for general guidance, the barrel should be cleaned after every 500 shots. Avoid the use of nitro-based cleaners as their chemicals can damage seals.

### STOCK

Periodically rub in a good quality stock oil to maintain the finish of walnut stocks. A furniture polish is recommended for laminate and Safari textured finish stocks. Use a mild detergent on a synthetic stock.

### MORE INFORMATION

More servicing information can be found online at the following.



[daystate.com/support](http://daystate.com/support) [daystateownersclub.com](http://daystateownersclub.com)





# RED WOLF | PARTS ASSEMBLY

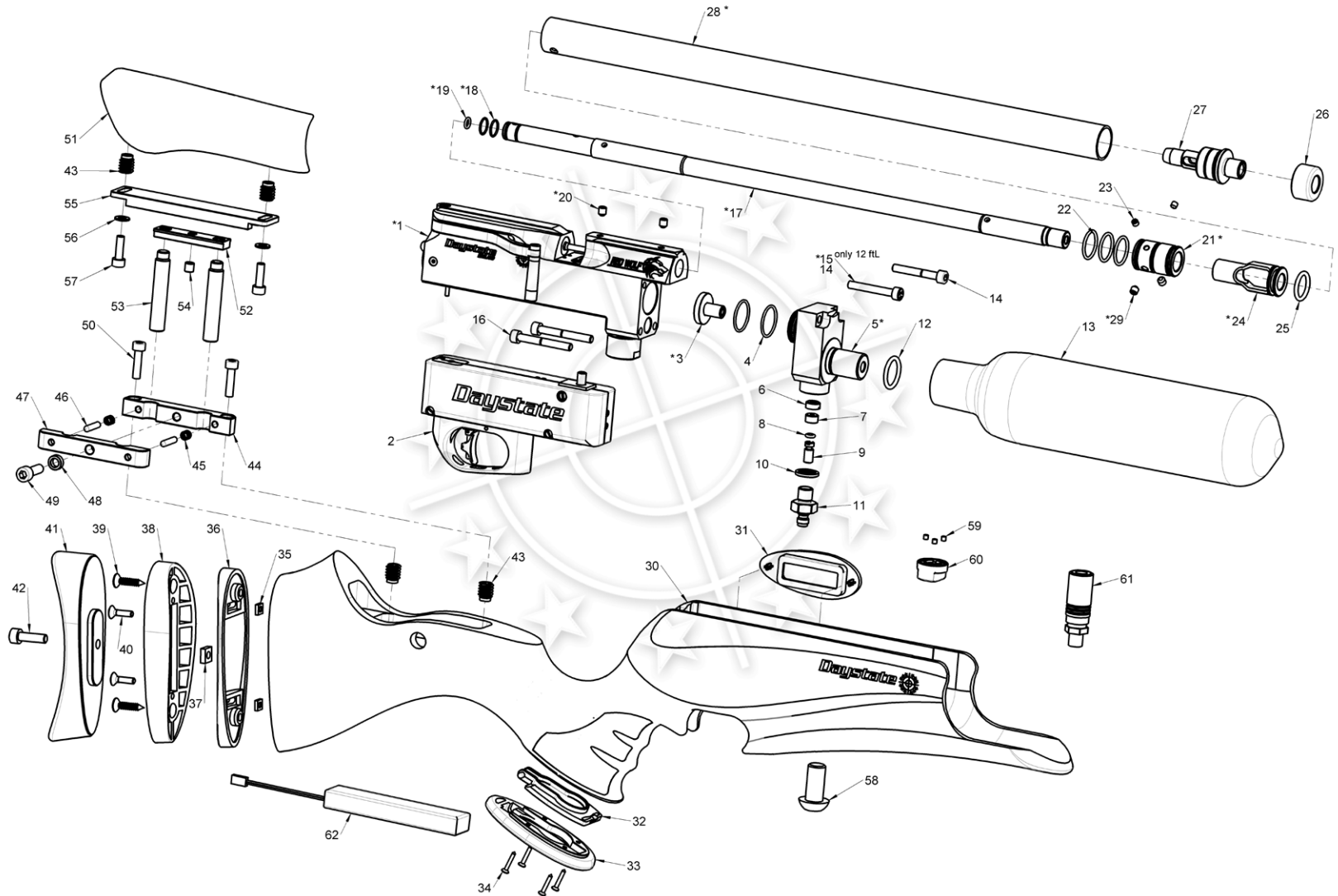

# RED WOLF | BREECH ASSEMBLY

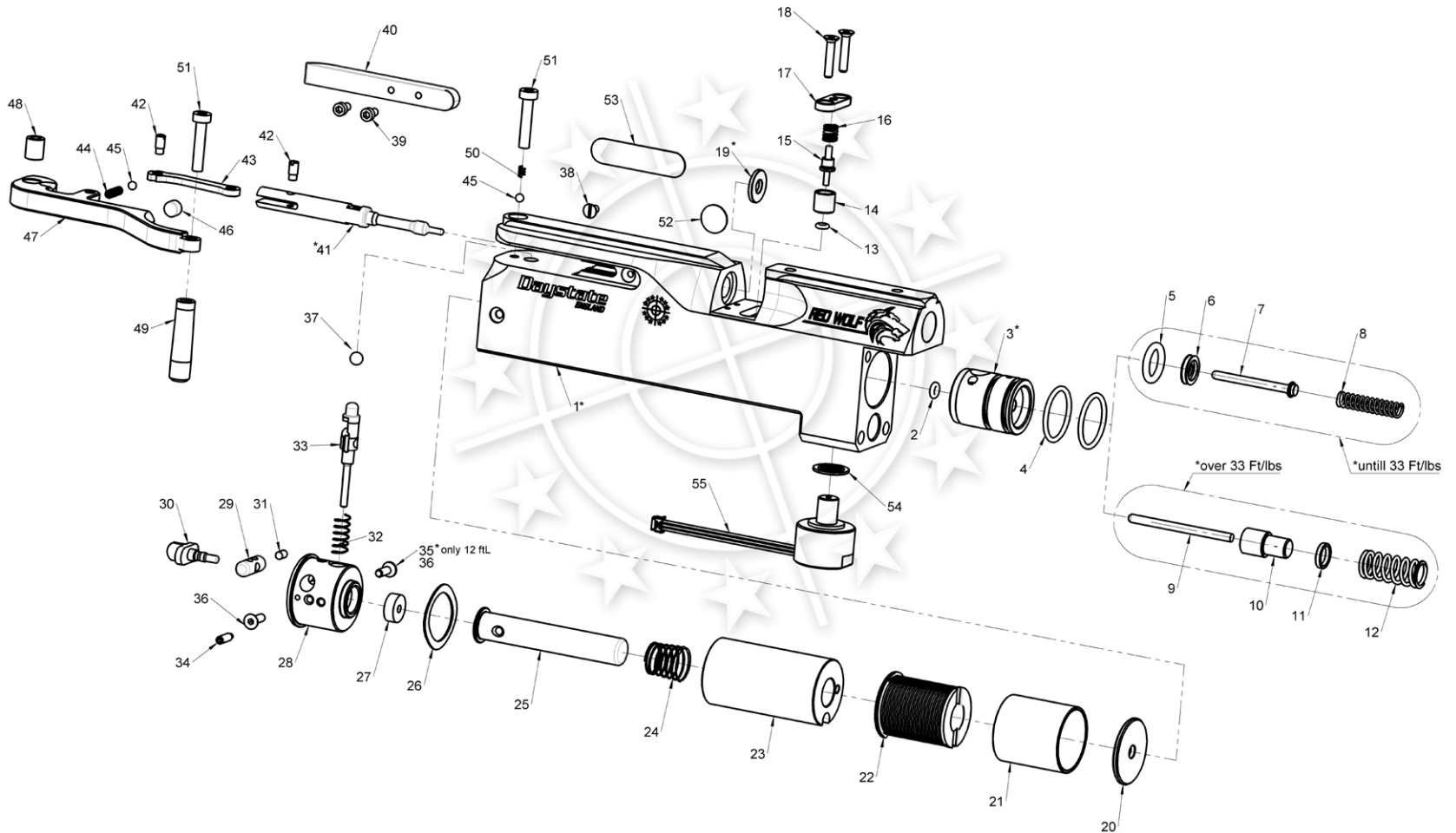

# WARRANTY INFORMATION

## 3 YEAR WARRANTY

All new Daystate rifles are guaranteed against faulty parts and labour for a period of three years from date of purchase (proof of purchase required). After this period, it is recommended that the rifle be returned to Daystate or its authorised agent for a scheduled service, and every three years subsequently. Servicing is charged at current rates. The warranty applies to the first purchase of a new rifle and is not transferable.

## EXCLUDED FROM WARRANTY

**Failure due to misuse or abuse, the fitting of non-standard parts, springs, seals, water-damage to wooden stocks, batteries and fair wear and tear. Daystate Ltd or its approved agent must carry out all maintenance and warranty work. The rifle must be maintained and used as outlined in this Official Handbook.**

Should a rifle be returned or collected under warranty, Daystate or its approved agent reserves the right to charge for postage and inspection costs.

A return form, which should be included with the rifle, can also be downloaded here:  
[daystate.com/wp-content/uploads/2018/05/Rifle-Return-Form.pdf](http://daystate.com/wp-content/uploads/2018/05/Rifle-Return-Form.pdf)



Ensure that the rifle is securely packed. Where possible, please remove stock, scope and other accessories to avoid the possibility of transit damage.

View the online handbook at:  
[daystate.com/support](http://daystate.com/support) for the latest information.

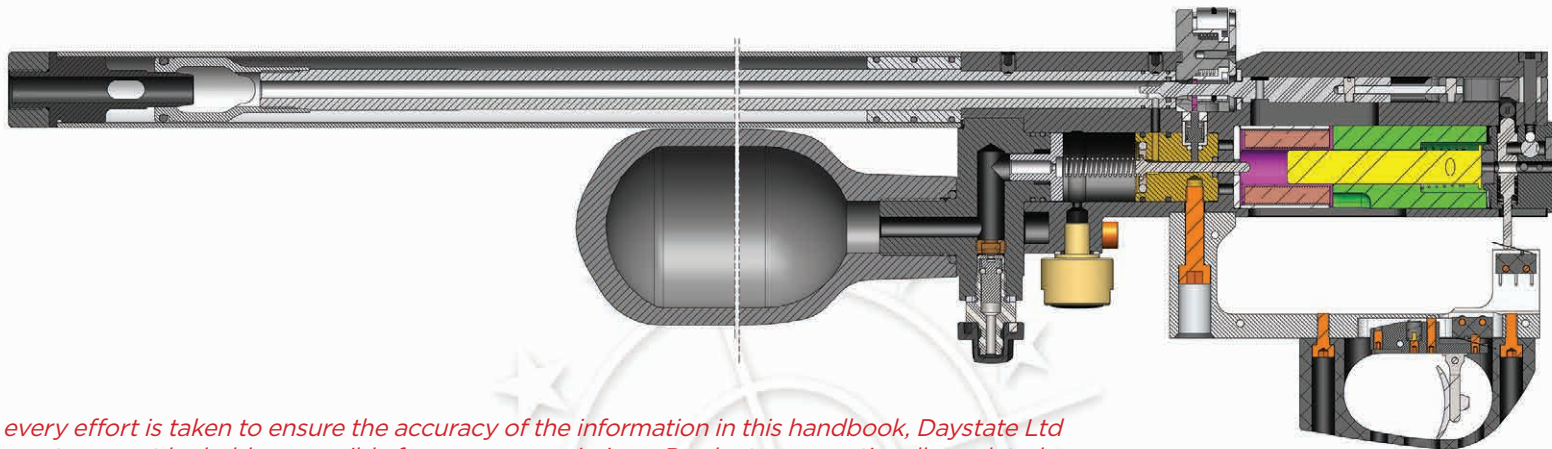

*While every effort is taken to ensure the accuracy of the information in this handbook, Daystate Ltd or its agents cannot be held responsible for errors or omissions. Products are continually updated and specification may change without notice.*



# NOTES



**Daystate** 



DAYSTATE LTD.  
UNIT 3, RALEIGH HALL INDUSTRIAL ESTATE, ECCLESHALL, STAFFORDSHIRE ST21 6JL, UK.

[daystate.com](https://www.daystate.com)  
[daystateownersclub.com](https://www.daystateownersclub.com)

© Daystate Ltd. 2023.v1. E&OE.